

MANHOLE COVER

C250T/900_001

MODEL: PETROL STATION

CLASS | C250

NORM | EN 124-5:2015

(test load 25 ton) For gully tops installed in the area of kerbside channels of roads which when measured from the kerb edge, extend a maximum of 0.5m into the carriageway and a maximum of 0.2m into the footway.

RESIN: self-extinguishing orthophthalic

MATRIX: glass fiber

PROCESS ADDITIVES AND REACTION PROMOTERS:

various additives

MANUFACTURING PROCESS:

SMC compression molding with prepregs



COVER

D	mm 1070
---	---------

h	mm 79
---	-------

FRAME

F	mm 1189
---	---------

C/O	mm 908
-----	--------

H	mm 100
---	--------

WEIGHT

COVER	kg 87,5
-------	---------

FRAME	kg 38,0
-------	---------

TOTAL	kg 125,5
-------	----------

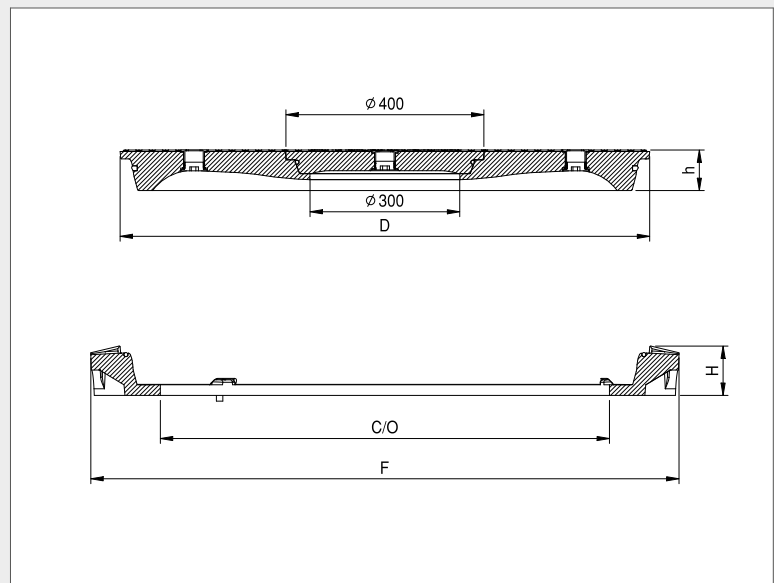

SURFACE DESIGN

14x14 square with T01 treatment

COLOUR

black RAL 9011

LIFTING KEY

Type 7 - Fixing Type 3

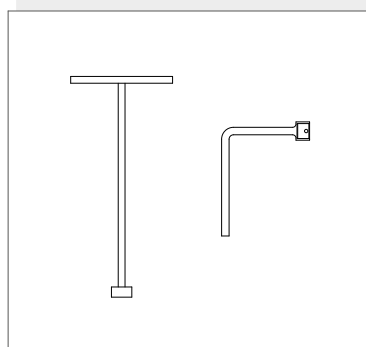

ACCESSORIES

LIFTING:

Eyelet - key Type 7- or lifting device
Type 6

FIXING:

rotating lock- key Type 3

SEALING:

yes