

MANHOLE COVER

C250T/600_001

MODEL: ROUND

CLASS | C250

NORM | EN 124-5:2015

(test load 25 ton) For gully tops installed in the area of kerbside channels of roads which when measured from the kerb edge, extend a maximum of 0.5m into the carriageway and a maximum of 0.2m into the footway.

RESIN: self-extinguishing orthophthalic

MATRIX: glass fiber

PROCESS ADDITIVES AND REACTION PROMOTERS:

various additives

MANUFACTURING PROCESS:

SMC compression molding with prepregs



COVER

D	mm 650
h	mm 40

FRAME

F	mm 760
C/O	mm 600
H	mm 60

WEIGHT

COVER	kg 25,6
FRAME	kg 8,6
TOTAL	kg 34,2

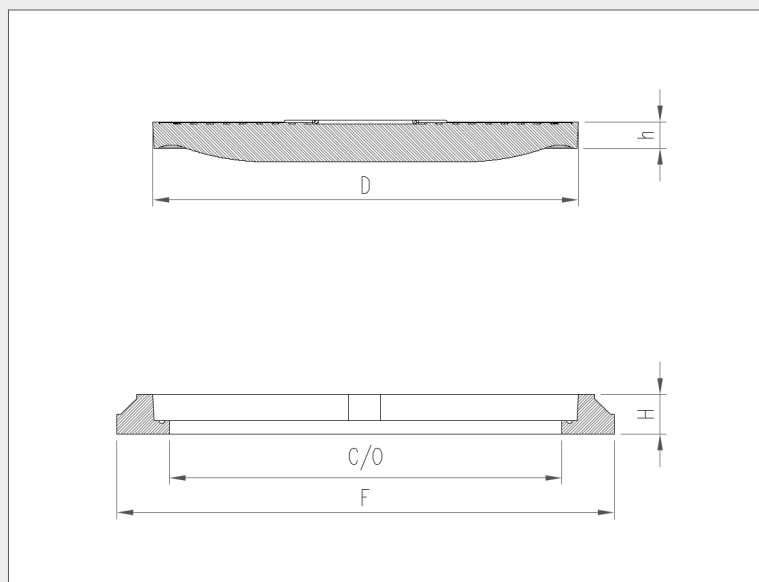

SURFACE DESIGN

14x14 square with T01 treatment

COLOUR

black RAL 9011

LIFTING KEY

type 2

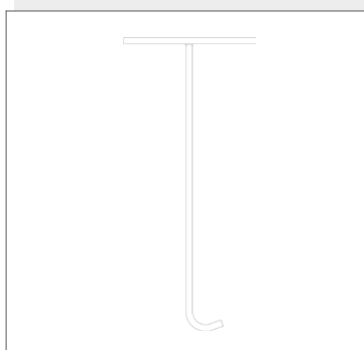

ACCESSORIES

LIFTING:
2 eye screws 2 washers 2 hexagonal nuts
FIXING:
1 screw TCE
SEALING:
yes (EPDM)