

MANHOLE COVER

B125T/600_001

MODEL: ROUND

CLASS | B125

NORM | EN 124-5:2015

(test load 12.5 ton) Footways, pedestrian areas and comparable areas, car parking decks.

RESIN: self-extinguishing orthophthalic

MATRIX: glass fiber

PROCESS ADDITIVES AND REACTION PROMOTERS:

various additives

MANUFACTURING PROCESS:

SMC compression molding with prepregs



COVER

D	mm 650
h	mm 26

FRAME

F	mm 780
C/O	mm 600
H	mm 40

WEIGHT

COVER	kg 15,6
FRAME	kg 5,4
TOTAL	kg 21,0

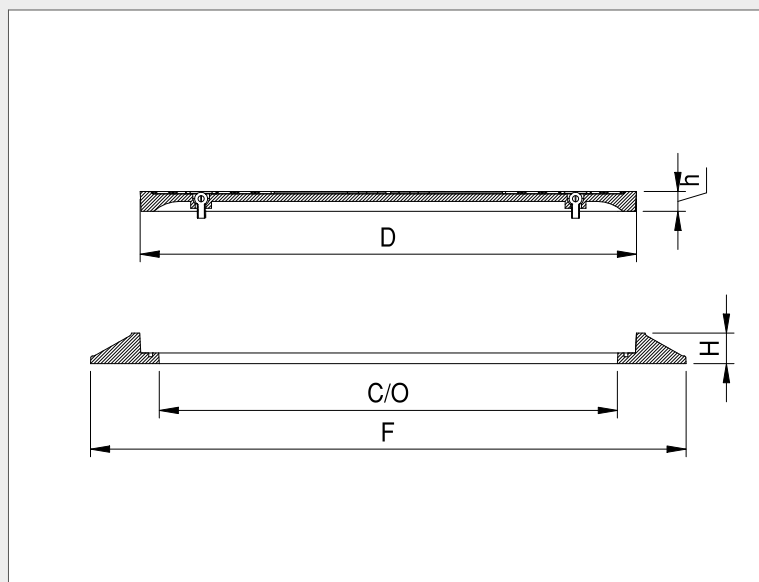

SURFACE DESIGN

14x14 square with T01 treatment

COLOUR

black RAL 9011

LIFTING KEY

type 2

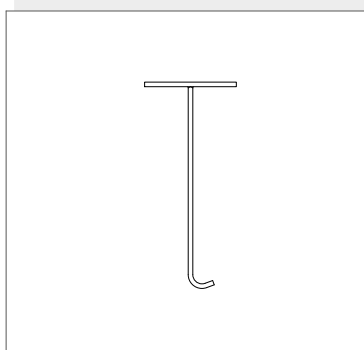

ACCESSORIES

LIFTING:
2 eye screws 2 washers 2 hexagonal nuts
FIXING:
2 screws TCE
SEALING:
yes (EPDM)