

## MANHOLE COVER

B125Q/900\_001

MODEL: SQUARE

CLASS | B125

NORM | EN 124-5:2015

(test load 12.5 ton) Footways, pedestrian areas and comparable areas, car parking decks.

**RESIN:** self-extinguishing orthophthalic

**MATRIX:** glass fiber

**PROCESS ADDITIVES AND REACTION PROMOTERS:**

various additives

**MANUFACTURING PROCESS:**

SMC compression molding with prepregs



### COVER

D	mm 1000X1000
h	mm 40

### FRAME

F	mm 1135X1135
C/O	mm 880X880
H	mm 70

### WEIGHT

COVER	kg 54,6
FRAME	kg 28,4
TOTAL	kg 83,0

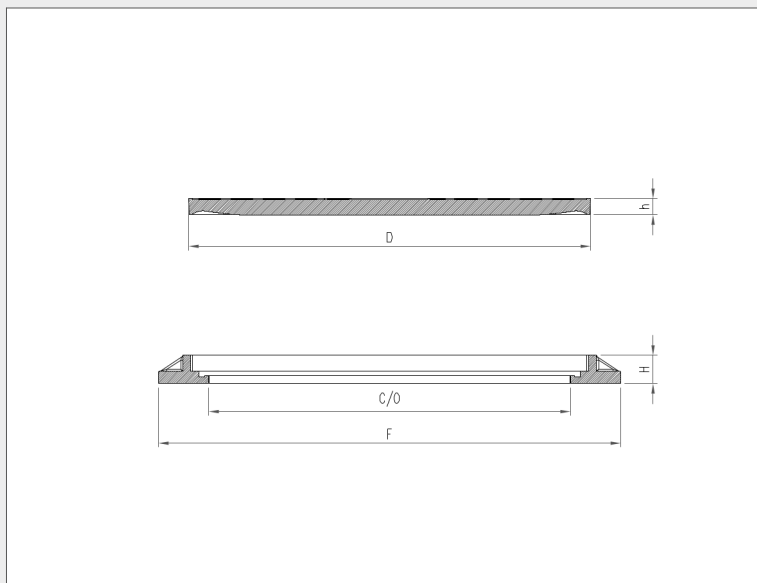

### SURFACE DESIGN

14x14 square with T01 treatment

### COLOUR

black RAL 9011

### LIFTING KEY

type 2

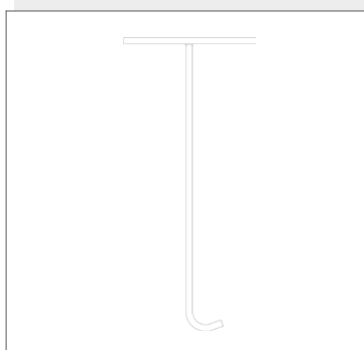

### ACCESSORIES

LIFTING:

2 eye screws 2 washers 2 hexagonal nuts

FIXING:

4 screws TCE