

MANHOLE COVER

B125Q/360_001

MODEL: SQUARE

CLASS | B125

NORM | EN 124-5:2015

(test load 12.5 ton) Footways, pedestrian areas and comparable areas, car parking decks.

RESIN: self-extinguishing orthophthalic

MATRIX: glass fiber

PROCESS ADDITIVES AND REACTION PROMOTERS:

various additives

MANUFACTURING PROCESS:

SMC compression molding with prepregs



COVER

D	mm 400x400
h	mm 40

FRAME

F	mm 515x515
C/O	mm 360x360
H	mm 60

WEIGHT

COVER	kg 8,4
FRAME	kg 7,1
TOTAL	kg 15,5

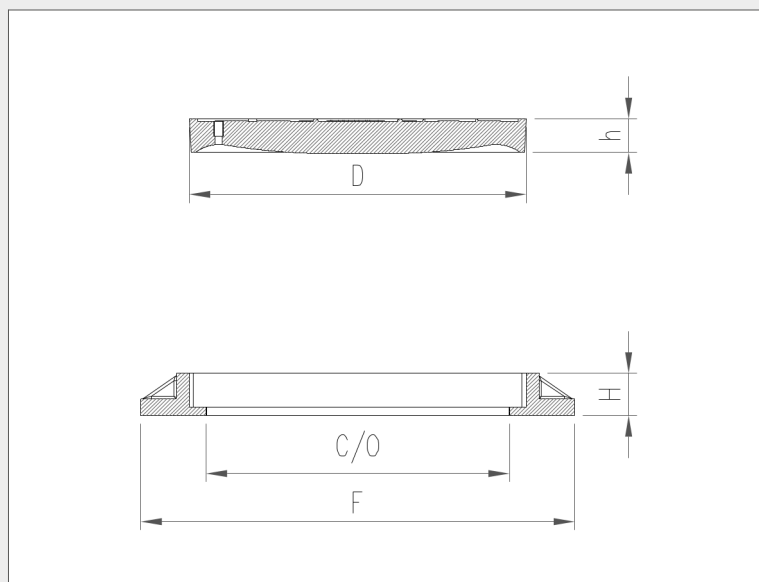

SURFACE DESIGN

14x14 square with T01 treatment

COLOUR

LIFTING KEY

type 2

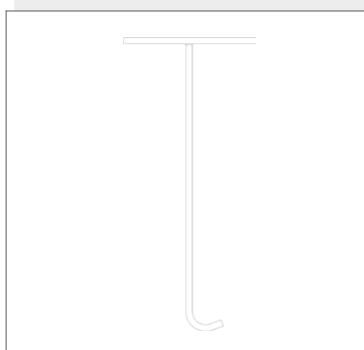

ACCESSORIES

LIFTING:

1 eye screw, 1 washer, 1 hexagonal nut